

**VT/TU Payload Processor/Performance Monitor for 622 Mbit/s**

**FEATURES**

The TUPP+622 chip offers the following features:

- A configurable, multi-channel, payload processor for alignment of SONET Virtual Tributaries or SDH Tributary Units in an STS-12/STM-4 or four STS-3/STM-1 byte serial data streams. Configurable to process any legal mix of tributaries.
- Provides independently-configurable AU3/AU4 frame format on incoming and outgoing directions.
- Compensates for pleisiochronous relationships between incoming and outgoing higher level (STS-1 to AU3) synchronous payload envelope frame rates through processing of the lower level (VT6 to TU11) tributary pointers.
- Provides for multiframe synchronization or ring closure at the head-end node in a SONET/SDH ring.
- Optionally frames to the H4 byte in the Path overhead to determine tributary multiframe boundaries.
- Inserts valid pointers, and all-zeros transport overhead bytes on the outgoing stream with valid "Telecombus" control signals.
- Independently-configurable incoming and outgoing interfaces that operate in 19.44 MHz or 77.76 MHz byte interface modes.
- Provides a standard JTAG test port for boundary scan board test purposes.
- Provides a generic 8-bit microprocessor bus interface.
- Low power 2.5V CMOS core logic/3.3V TTL compatible inputs and outputs
- Available in a 304-pin SBGA package.
- Supports industrial temperature range (-40°C to 85°C) operation.

**PER-TRIBUTARY FUNCTIONS**

The TUPP+622 chip offers the following per-tributary functions:

- Detects Loss Of Pointer and reacquisition.
- Performs lower channel supervision for Intermediate Performance Monitoring in SONET/SDH rings.

- Extracts and serializes the entire tributary Path overhead of each tributary.
- Detects tributary elastic store underflow and overflow errors.
- Stores and processes 16-byte or 64-byte format tributary Path trace messages (tributary trail trace identifiers). Detects tributary Path Trace Mismatch and unstable alarms.
- Detects tributary Path Signal Label Mismatch and unstable alarms.
- Extracts tributary Path signal label into internal registers and detects Change of Tributary Path Signal Label events for each tributary.
- Detects tributary unequipped defect, tributary Path Defect Indication, and the assertion and removal of tributary extended Remote Defect Indications.
- Extracts and stores tributary size bits.
- Calculates and compares the tributary Path BIP-2 error detection code. Accumulates the BIP-2 errors and tributary Path Remote Error Indications on a block or bit basis.
- Supports in-band error reporting by updating REI, RDI, and auxiliary RDI bits in the V5 byte (G1 in TU3) with the status of the incoming stream.
- Optionally generates tributary Path AIS on the detection of LOP, loss of tributary multiframe, trace identifier unstable, trace identifier mismatch, signal label unstable, and/or signal label mismatch. Also allows software to force AIS insertion.
- Under software control, allows insertion of all-zeros or all-ones tributary idle code with unequipped indication.

**APPLICATIONS**

Use the TUPP+622 chip in the following applications:

- SONET/SDH Add/Drop and Terminal Multiplexers
- SONET/SDH Broadband Cross-Connects
- SONET/SDH and ATM Test Equipment

**BLOCK DIAGRAM**

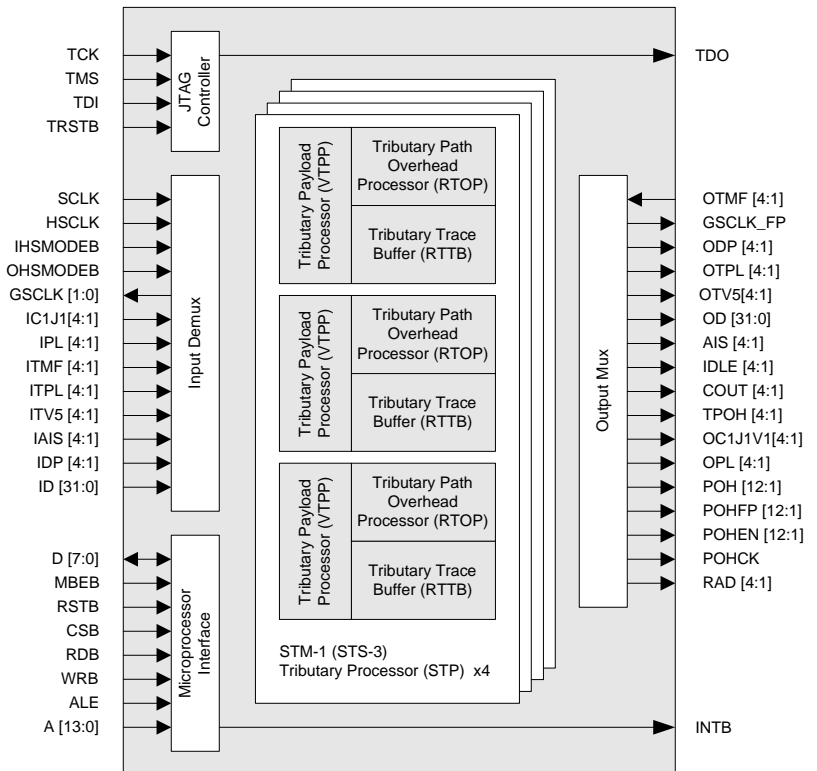

**VT/TU Payload Processor/Performance Monitor for 622 Mbit/s**

**TYPICAL APPLICATIONS**

**STS-12/STM-4 AGGREGATE-INTERFACE WITH TRIBUTARY-PROCESSING AND PERFORMANCE-MONITORING**

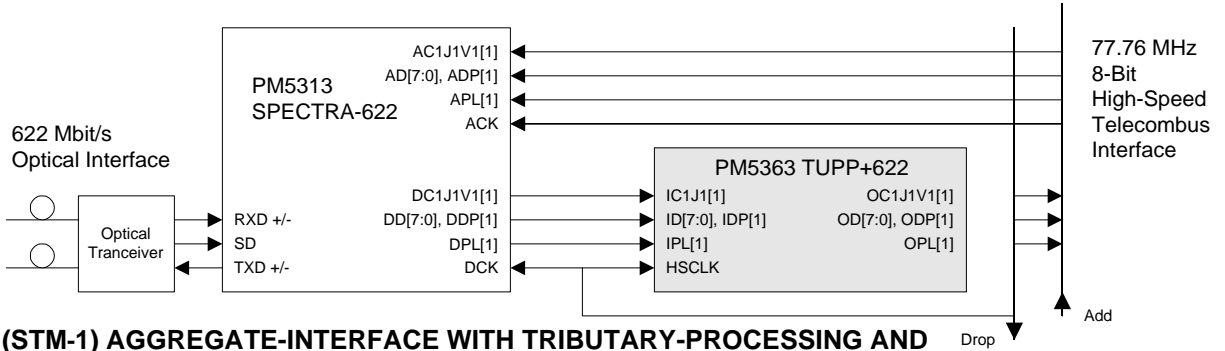

**QUAD STS-3 (STM-1) AGGREGATE-INTERFACE WITH TRIBUTARY-PROCESSING AND PERFORMANCE-MONITORING**

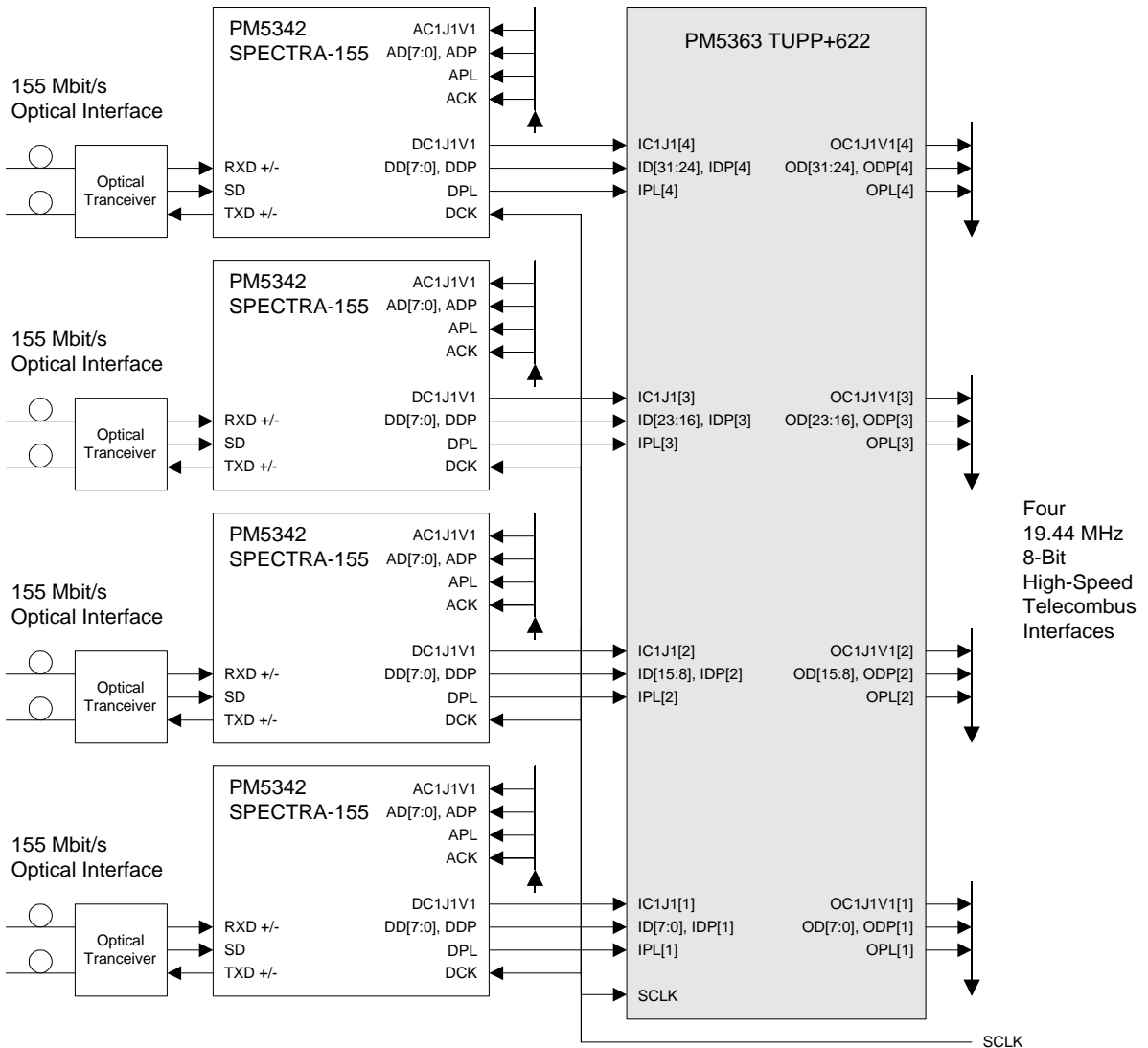

Head Office:  
 PMC-Sierra, Inc.  
 8555 Baxter Place  
 Burnaby, B.C. V5A 4V7  
 Canada  
 Tel: 604.415.6000  
 Fax: 604.415.6200

To order documentation,  
 send email to:  
 document@pmc-sierra.com  
 or contact the head office,  
 Attn: Document Coordinator

All product documentation is available  
 on our web site at:  
<http://www.pmc-sierra.com>  
 For corporate information,  
 send email to:  
 info@pmc-sierra.com

PMC-1981272 (R3)  
 © 2001 PMC-Sierra, Inc.