

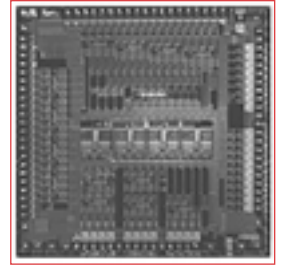

# BCM3118B PRODUCT Brief



## BCM3118B QAMLINK® DVB/DAVIC RECEIVER

### BCM3118B FEATURES

- **Downstream QAM receiver for international applications**
- **Integrated QAMLink receiver with Forward Error Correction (FEC)**
  - 1-7 MBaud variable symbol rate receiver
  - Supports variable channelization
  - Supports 4, 16, 32, 64, 128 and 256-QAM
  - Digital demodulator, Nyquist filters, tracking loops, and 20-tap adaptive decision feedback equalizer
  - Digital derotator for wideband carrier phase tracking
- **DVB/DAVIC-compliant FEC decoder**
  - Reed-Solomon (N,K) = 204,188; t=8
  - Convolutional deinterleaver, I=1-12 with internal RAM, I=204 with external RAM
- **I<sup>2</sup>C or SPI-compatible microcontroller interface**
- **Integrated 10-bit analog-to-digital converter**
- **On-chip generation of all clock and control signals**
- **JTAG test interface**
- **100-pin PQFP Package**

### SUMMARY OF BENEFITS

- **Fully-integrated solution enables less-complex, low-cost cable modems and cable-TV set-top boxes**
- **Significantly increases channel capacity**
- **Variable data rates enable systems to adapt to channels encoded at different data rates**
- **Integrated A/D converter reduces system manufacturing costs and complexity**
- **A universal chip solution that supports DVB, DAVIC, ITU-T J.83/Annex A and Annex C, IEEE 802.14-based systems**
- **Digital adaptive equalizers ensure robust performance in the presence of multipath reflections**

Interactive Set-top Box with DOCSIS and Watch and Record Dual Video Channels

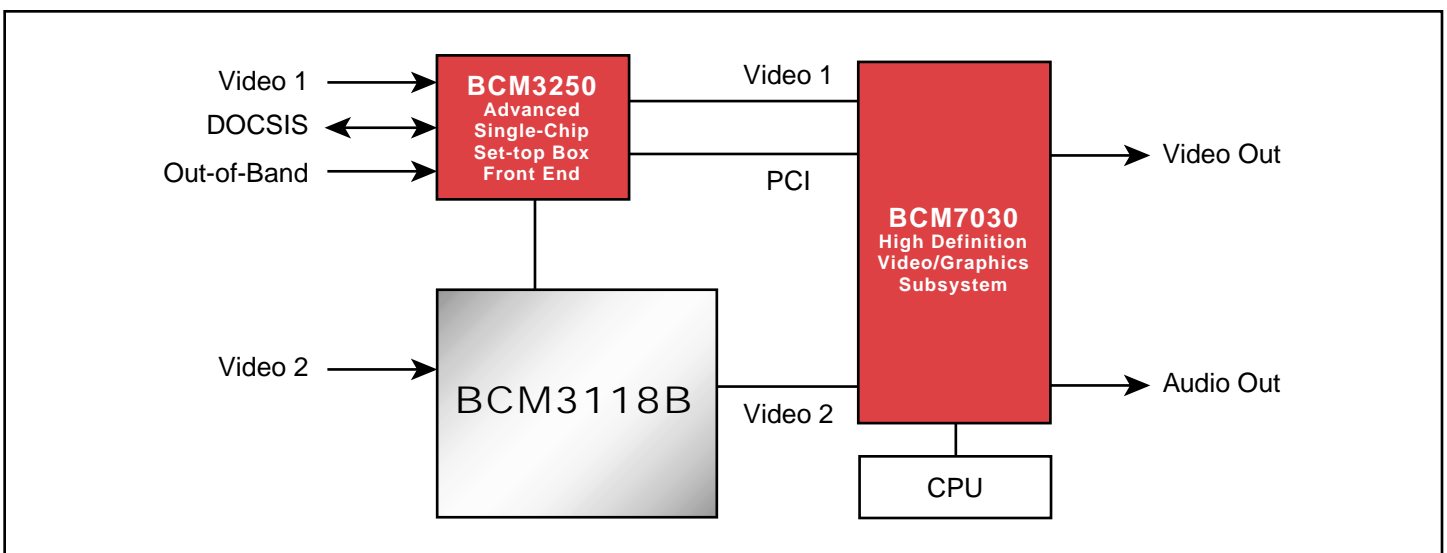

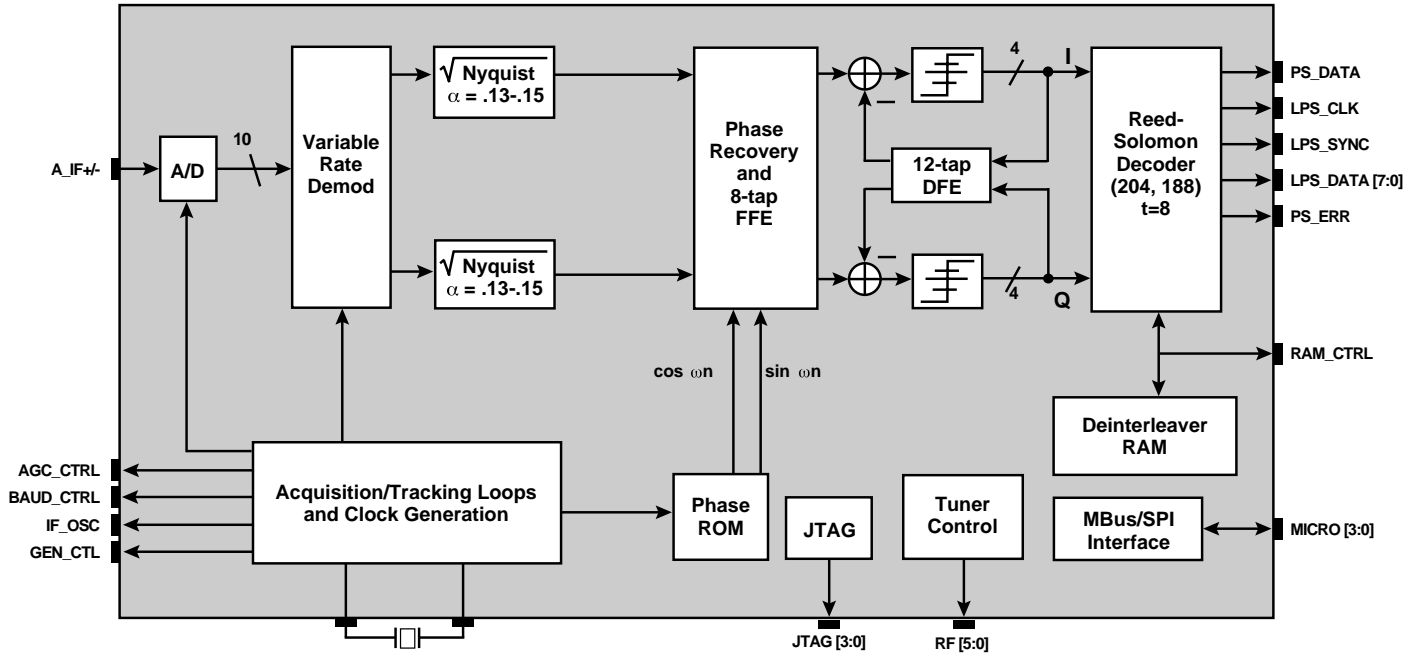

The **BCM3118B** QAMLink DVB/DAVIC Receiver with FEC is an integrated digital transmission solution for cable modems, cable-TV set-top boxes and digital microwave radios. Its bandwidth-efficient feature set expands the existing potential bandwidth of a standard analog network and provides operators with reliable, error-free transmission. Optimized for high-volume manufacturing, the **BCM3118B** is a highly integrated solution that reduces the system-level chip count, the cost, and the complexity associated with manufacturing RF receivers.

A single-chip solution, the **BCM3118B** has a 10-bit A/D converter, a 256-QAM demodulator with square-root raised-cosine receive filters, an adaptive equalizer with an embedded phase recovery derotator, acquisition and tracking loops, and a DVB/DAVIC-compliant Reed-Solomon FEC decoder with deinterleaver. The demodulator supports QPSK, 16, 32, 64, 128 and 256-QAM formats and adapts to channels encoded at different data rates up to 56 Mbps. The equalizer in the **BCM3118B** achieves transmission performance within 1 dB of theory over worse-case channels with multipath delays as long as 2.4 microseconds at 5 MBaud or 1.7 microseconds at 7 MBaud and amplitudes within .5 dB of the desired signals. With this level of performance, the **BCM3118B** combats the effects of channel distortions commonly found in cable-TV systems. The

Broadcom® and the pulse logo® are registered trademarks of Broadcom Corporation. QAMLink is a trademark of Broadcom Corporation.

For more information please contact us at:  
 Phone: 949-450-8700, FAX: 949-450-8710  
 Email: info@broadcom.com

**BCM3118B** has an integrated A/D converter, which eliminates the costs associated with fine tuning of external components during high-volume production.

The **BCM3118B** samples the analog IF waveform being delivered to **BCM3118B** by the integrated A/D converter. The signal is then digitally mixed to baseband and filtered by dual square-root Nyquist filters. Inter-symbol interference is then removed by the adaptive decision feedback equalizer. A decision slicer, which supports constellations up to 256-QAM, formats the equalized data. The data is then fed into a DVB/DAVIC-compliant synchronization block, deinterleaver, Reed-Solomon FEC, and derandomizer. The final error-corrected output is delivered in an MPEG-2 transport format.

The **BCM3118B** can be used as a stand-alone chip or with Broadcom's BCM3250 for a complete watch and record solution with EuroDOCSIS. Compliant with the ITU-T J83/Annex A and Annex C, DVB/DAVIC and the IEEE802.14 cable transmission standards for QAM downstream, the **BCM3118B** is a universal downstream solution for worldwide coaxial cable applications.



Visit our web site at: [www.broadcom.com](http://www.broadcom.com)