

DV74HCT257 Available Q2, 1995

### Quad 2-Input Data Selector/ Multiplexer with 3-State Outputs

This device selects a 4-bit nibble from either A or B inputs as determined by the Select input. The nibble is presented at the outputs in noninverted form when the Output Enable pin is at a low level. A high level on the Output Enable pin switches the outputs into the high-impedance state. The HC257 is similar in function to the HC157 which does not have 3-state outputs.

- Output Drive Capability: 15 LSTTL Loads
- Outputs Directly Interface to CMOS, NMOS, and TTL
- Operating Voltage Range: 2 to 6 V for HC device
- Low Input Current: 1  $\mu$ A
- DC, AC parameters guaranteed from -55°C to 125°C

**DV74HC257**  
**DV74HCT257**

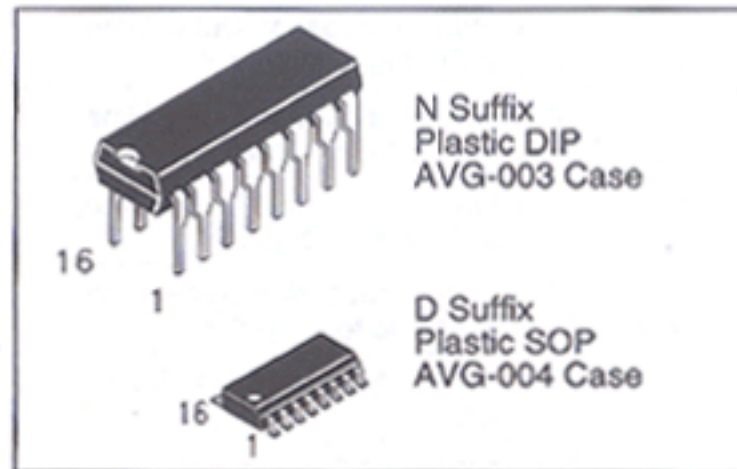

257

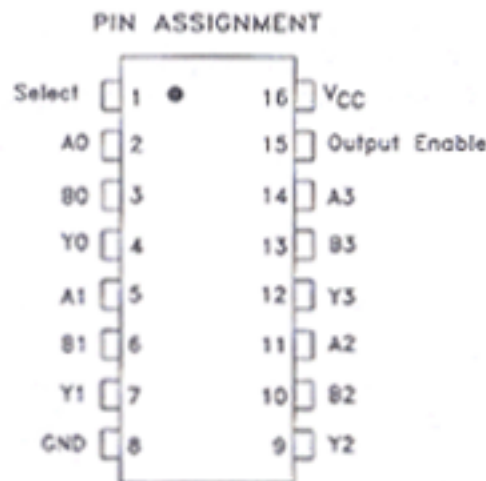
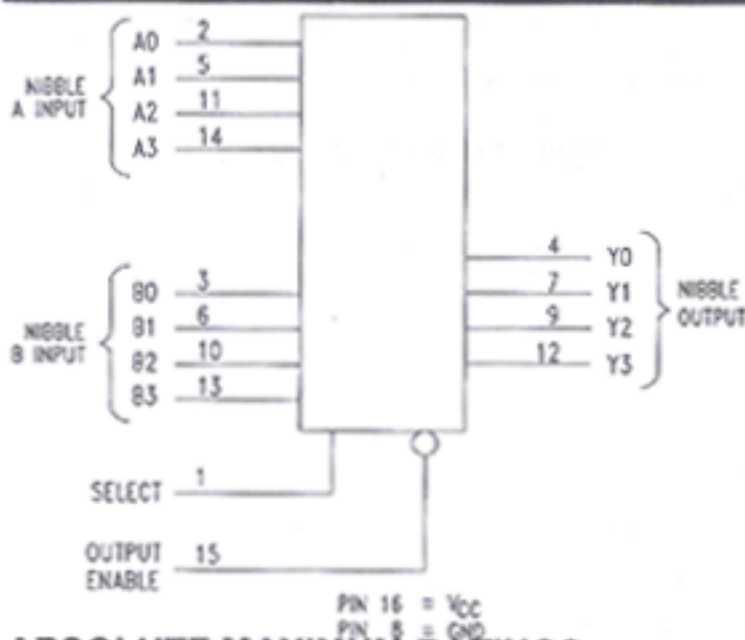

#### TRUTH TABLE

Inputs		Outputs
Output Enable	Select	Y0-Y3
H	X	Z
L	L	A0-A3
L	H	B0-B3

H = High Logic Level  
L = Low Logic Level  
A0-A3, B0-B3 = the levels of the respective Nibble Inputs  
Z=High Impedance  
X = Don't Care

#### ABSOLUTE MAXIMUM RATINGS

Maximum ratings are those values beyond which damage to the device may occur.

Symbol	Parameter	Value	Unit
V <sub>CC</sub>	DC Supply Voltage (Referenced to GND)	-0.5 to +7.0	V
V <sub>IN</sub>	DC Input Voltage (Referenced to GND)	-1.5 to V <sub>CC</sub> +1.5	V
V <sub>OUT</sub>	DC Output Voltage (Referenced to GND)	-0.5 to V <sub>CC</sub> +0.5	V
I <sub>IN</sub>	DC Input Current, per Pin	± 20	mA
I <sub>OUT</sub>	DC Output Current, per Pin	± 35	mA
I <sub>CC</sub>	DC Supply Current, V <sub>CC</sub> and GND Pins	± 75	mA
P <sub>D</sub>	Power Dissipation in Still Air, Plastic DIP SOP Package	750 500	mW
T <sub>STG</sub>	Storage Temperature Range	-65 to +150	°C
T <sub>L</sub>	Lead Temperature, 1mm from Case for 10 Seconds	260	°C

#### GUARANTEED OPERATING CONDITIONS

Symbol	Parameter	Min	Max	Unit
V <sub>CC</sub>	DC Supply Voltage HC(HCT), Referenced to GND	2.0(4.5)	6.0(5.5)	V
V <sub>IN</sub> , V <sub>OUT</sub>	DC Input Voltage, Output Voltage, Referenced to GND	0	V <sub>CC</sub>	V
T <sub>A</sub>	Ambient Temperature	-55	+125	°C
t <sub>r</sub> , t <sub>f</sub>	Input Rise and Fall Time: HC: V <sub>CC</sub> =2.0V HCT: V <sub>CC</sub> =5.5V / HC: V <sub>CC</sub> =4.5V HC: V <sub>CC</sub> =6.0V	0	1000 500 400	ns

DC ELECTRICAL CHARACTERISTICS

Symbol	Parameter	Conditions	V <sub>CC</sub> V	Guaranteed Limits			Unit
				25°C to -55°C	≤85°C	≤125°C	
V <sub>IH</sub>	Minimum High-Level Input Voltage	I <sub>OUT</sub>   ≤ 20 μA	2.0	1.5	1.5	1.5	V
			4.5	3.15	3.15	3.15	
			6.0	4.2	4.2	4.2	
V <sub>IL</sub>	Maximum Low-Level Input Voltage	I <sub>OUT</sub>   ≤ 20 μA	2.0	0.3	0.3	0.3	V
			4.5	0.9	0.9	0.9	
			6.0	1.2	1.2	1.2	
V <sub>OH</sub>	Minimum High-Level Output Voltage	V <sub>IN</sub> = V <sub>IH</sub> or V <sub>IL</sub>  I <sub>OUT</sub>   ≤ 20 μA	2.0	1.9	1.9	1.9	V
			4.5	4.4	4.4	4.4	
		V <sub>IN</sub> = V <sub>IH</sub> or V <sub>IL</sub> ,  I <sub>OUT</sub>   ≤ 6.0 mA  I <sub>OUT</sub>   ≤ 7.8 mA	4.5	3.98	3.84	3.7	
			6.0	5.48	5.34	5.2	
V <sub>OL</sub>	Maximum Low Level Output Voltage	V <sub>IN</sub> = V <sub>IH</sub> or V <sub>IL</sub>  I <sub>OUT</sub>   ≤ 20 μA	2.0	0.1	0.1	0.1	V
			4.5	0.1	0.1	0.1	
		V <sub>IN</sub> = V <sub>IH</sub> or V <sub>IL</sub> ,  I <sub>OUT</sub>   ≤ 6.0 mA  I <sub>OUT</sub>   ≤ 7.8 mA	4.5	0.26	0.33	0.40	V
			6.0	0.26	0.33	0.40	
I <sub>IN</sub>	Maximum Input Leakage Current	V <sub>IN</sub> = V <sub>CC</sub> or GND	6.0	± 0.1	± 1.0	± 1.0	μA
I <sub>OZ</sub>	Maximum Three-State Leakage Current	Output in High-Impedance State V <sub>in</sub> = V <sub>IL</sub> or V <sub>IH</sub> V <sub>out</sub> = V <sub>CC</sub> or GND	6.0	± 0.5	± 5.0	± 10.0	μA
I <sub>CC</sub>	Maximum Quiescent Supply Current (Per Package)	V <sub>IN</sub> = V <sub>CC</sub> or GND  I <sub>OUT</sub>   = 0 μA	6.0	8.0	80	160	μA

AC ELECTRICAL CHARACTERISTICS over full operating conditions (C<sub>L</sub> = 50 pF, Input t<sub>f</sub> = t<sub>r</sub> = 6 ns)

Symbol	Parameter	V <sub>CC</sub> V	Guaranteed Limit			Unit
			25°C to -55°C	≤85°C	≤125°C	
t <sub>PLH</sub> , t <sub>PHL</sub>	Maximum Propagation Delay Time, Nibble A or B to Output Y	2.0	100	125	150	ns
		4.5	20	25	30	
		6.0	17	21	26	
t <sub>PLH</sub> , t <sub>PHL</sub>	Maximum Propagation Delay Time, Select to Output Y	2.0	100	125	150	ns
		4.5	20	25	30	
		6.0	17	21	26	
t <sub>PLZ</sub> , t <sub>PHZ</sub>	Maximum Propagation Delay Time, Output Disable to Output Y	2.0	150	190	225	ns
		4.5	30	38	45	
		6.0	26	33	38	
t <sub>PZL</sub> , t <sub>PZH</sub>	Maximum Propagation Delay Time, Output Enable to Output Y	2.0	150	190	225	ns
		4.5	30	38	45	
		6.0	26	33	38	
t <sub>TLH</sub> , t <sub>THL</sub>	Maximum Output Transition Time Any Output	2.0	60	75	90	ns
		4.5	12	15	18	
		6.0	10	13	15	
C <sub>IN</sub>	Maximum Input Capacitance	—	10	10	10	pF
C <sub>OUT</sub>	Maximum Three-State Output Capacitance (Output High-Impedance)	—	15	15	15	pF

C <sub>PD</sub>	Power Dissipation Capacitance (Per Multiplexer) Used to determine the no-load dynamic power consumption, P <sub>D</sub> = C <sub>PD</sub> V <sub>CC</sub> <sup>2</sup> f + I <sub>CC</sub> V <sub>CC</sub>	Typical @ 25°C, V <sub>CC</sub> = 5 V			pF
		39			

## DC ELECTRICAL CHARACTERISTICS

Symbol	Parameter	Conditions	V <sub>CC</sub> (V)	Guaranteed Limits			Unit
				25°C to -55°C	≤ 85°C	≤ 125°C	
V <sub>IH</sub>	Minimum High Level Input Voltage	V <sub>OUT</sub> = V <sub>CC</sub> -0.1 V  I <sub>OUT</sub>   ≤ 20 μA	4.5	2.0	2.0	2.0	V
			5.5	2.0	2.0	2.0	
V <sub>IL</sub>	Maximum Low Level Input Voltage	V <sub>OUT</sub> = 0.1V or V <sub>CC</sub> -0.1 V  I <sub>OUT</sub>   ≤ 20 μA	4.5	0.8	0.8	0.8	V
			5.5	0.8	0.8	0.8	
V <sub>OH</sub>	Minimum High Level Output Voltage	V <sub>IN</sub> = V <sub>IH</sub>  I <sub>OUT</sub>   ≤ 20 μA	4.5	4.4	4.4	4.4	V
			5.5	5.4	5.4	5.4	
V <sub>OL</sub>	Maximum Low Level Output Voltage	V <sub>IN</sub> = V <sub>IH</sub>  I <sub>OUT</sub>   ≤ 6.0 mA	4.5	3.98	3.84	3.70	V
			5.5	0.1	0.1	0.1	
V <sub>OL</sub>	Maximum Low Level Output Voltage	V <sub>IN</sub> = V <sub>IL</sub>  I <sub>OUT</sub>   ≤ 20 μA	4.5	0.1	0.1	0.1	V
			5.5	0.1	0.1	0.1	
V <sub>OL</sub>	Maximum Low Level Output Voltage	V <sub>IN</sub> = V <sub>IL</sub>  I <sub>OUT</sub>   ≤ 6.0 mA	4.5	0.26	0.33	0.40	V
			5.5	0.1	0.1	0.1	
I <sub>IN</sub>	Maximum Input Leakage Current	V <sub>IN</sub> =V <sub>CC</sub> or GND, Pins 1 or 19	5.5	±0.1	±1.0	±1.0	μA
I <sub>OZ</sub>	Maximum 3-State Current (Output in High Impedance State)	V <sub>IN</sub> =V <sub>IL</sub> or V <sub>IH</sub> V <sub>OUT</sub> =V <sub>CC</sub> or GND, I/O Pins	5.5	±0.5	±5.0	±10.0	mA
I <sub>CC</sub>	Maximum Quiescent Supply Current	V <sub>IN</sub> = V <sub>CC</sub> or GND I <sub>OUT</sub> = 0 μA	6.0	4	40	160	μA
ΔI <sub>CC</sub>	Additional Quiescent Supply Current (per Package)	V <sub>IN</sub> =2.4 V, Any One Input V <sub>IN</sub> = V <sub>CC</sub> or GND, Other Inputs I <sub>OUT</sub> = 0 μA	5.5	-55°C to 25°C 2.9	25°C to 125°C 2.4		mA

257

## AC ELECTRICAL CHARACTERISTICS over full operating conditions (C<sub>L</sub>=50pF, Input t<sub>r</sub>=t<sub>f</sub>=6ns)

Symbol	Parameter	V <sub>CC</sub> V	Guaranteed Limit			Unit
			25°C to -55°C	≤85°C	≤125°C	
t <sub>PLH</sub> , t <sub>PHL</sub>	Maximum Propagation Delay Time, Input D to Output Y or $\bar{Y}$	5.0 ±10%	37	46	56	ns
t <sub>PLH</sub> , t <sub>PHL</sub>	Maximum Propagation Delay Time, Input A to Output Y or $\bar{Y}$		41	51	62	ns
t <sub>PLZ</sub> , t <sub>PHZ</sub>	Maximum Propagation Delay Time, Output Enable to Output Y		39	49	59	ns
t <sub>PZL</sub> , t <sub>PZH</sub>	Maximum Propagation Delay Time, Output Enable to Output Y		29	36	44	ns
t <sub>PLZ</sub> , t <sub>PHZ</sub>	Maximum Propagation Delay Time, Output Enable to Output $\bar{Y}$		44	55	66	ns
t <sub>PZL</sub> , t <sub>PZH</sub>	Maximum Propagation Delay Time, Output Enable to Output $\bar{Y}$		30	38	45	ns
t <sub>TLH</sub> , t <sub>THL</sub>	Maximum Output Transition Time Any Output		15	19	22	ns
C <sub>IN</sub>	Maximum Input Capacitance		—	10	10	10
C <sub>OUT</sub>	Maximum Three-State Output Capacitance (Output High-Impedance)	—	15	15	15	pF
C <sub>PD</sub>	Power Dissipation Capacitance (Per Package) Used to determine the no-load dynamic power consumption, P <sub>D</sub> = C <sub>PD</sub> V <sub>CC</sub> <sup>2</sup> f + I <sub>CC</sub> V <sub>CC</sub>	Typical @ 25°C, V <sub>CC</sub> = 5 V			pF	
		36				

# SWITCHING WAVEFORMS

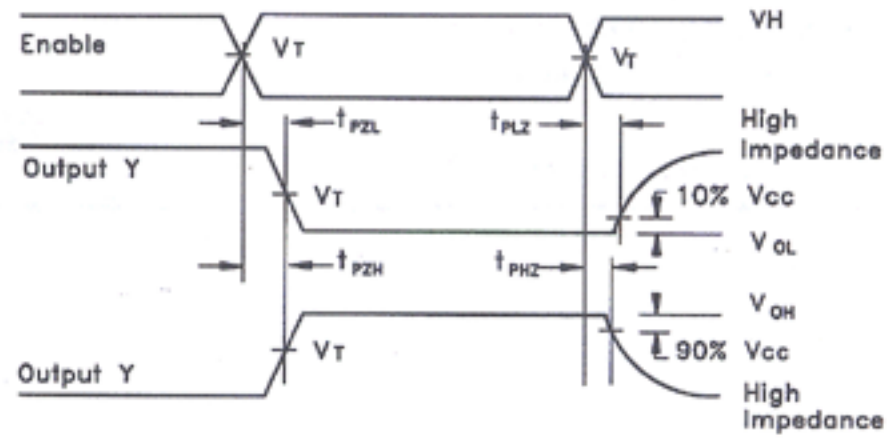
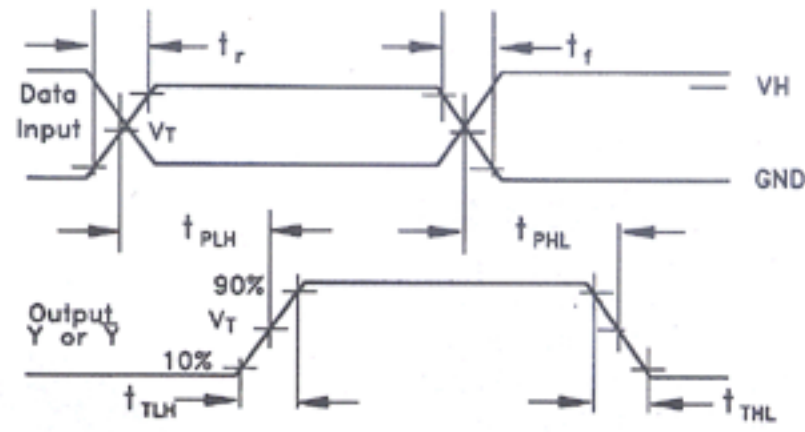

Input and Output Threshold Voltage:  $V_T = 50\% V_{CC}$  for HC, 1.3V for HCT,  $V_H = V_{CC}$  for HC, 3V for HCT